



REFRIGERATION

CENTER OF ALL YOUR FOOD SERVICE NEEDS

70" REFRIGERATED PREP TABLE WITH 3 Doors

Item #: 24267

Model: PT-CN-1778

*High Performance
and Quality
Refrigerated Prep Table*

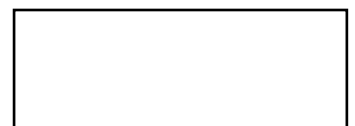

Authorized Dealer



NEMA
5-20
125 VAC / 20 AMP



REFRIGERATION

70" REFRIGERATED PREP TABLE WITH 3 DOORS



Detail Shots



This refrigerator provides ample storage space and a 3/4" cutting board / work area. Constructed of stainless steel and features self-closing doors.

Features:

- 430 Stainless Steel exterior
- 304 Stainless Steel interior
- Mechanical Temperature controller
- Removable door gasket
- Plastic coated shelves.
- European controller and compressor
- 3/4" thick cutting board
- The units automatically defrost
- Polyurethane insulation
- Self-closing doors
- Casters

(Inserts not included)

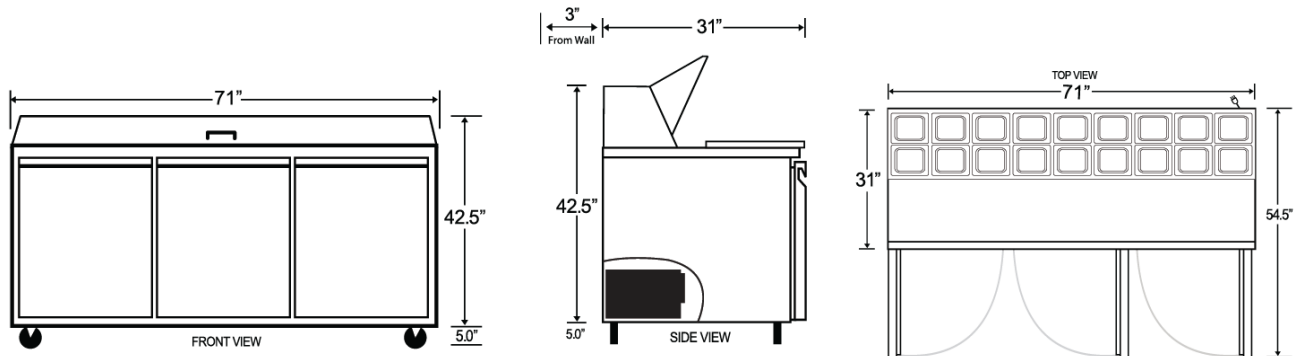

PRODUCT SPECIFICATIONS

ITEM NUMBER	24267	COOLING SYSTEM	Ventilated
MODEL	PT-CN-1778	INSERT CAPACITY	eighteen 1/6 pans
DESCRIPTION	70" Refrigerator	NUMBER OF DOORS	3
TEMPERATURE RANGE	0°C ~ 10°C/ 32°F ~ 50°F	NUMBER OF SHELVES	3
MAX AMBIENT TEMP RATING	90°F	SHELF CAPACITY	90 lbs.
HORSEPOWER	0.99 HP	EXTERIOR DIMENSIONS (WDH)	70" x 29.5" x 42.3"
PHASE	1	INTERIOR DIMENSIONS (WDH)	66.4" x 23.82" x 23.5"
ELECTRICAL	110 V / 60 Hz	PACKAGING DIMENSIONS	76" x 34" x 45.5"
AMPS	8.8	NET VOLUME (CU. FT.)	15.55 cu. ft.
REFRIGERANT	R134a	WEIGHT	386 lbs.
ISOLATION MATERIAL	R141b	PACKAGING WEIGHT	496 lbs.

OMCAN INC.

Telephone: 1-800-465-0234
 Fax: (905) 607-0234
 E-mail: sales@omcan.com
 Website: www.omcan.com



Follow us to keep up to date with the latest news and offers

